

Intellivox DDC2.0 (Digital Directivity Control)

DDC stands for Digital Directivity Control, the 2.0 represents that this is the second generation of Intellivox DDC products from Duran Audio. DDC is a multi-channel loudspeaker array technology where the single loudspeaker elements are positioned in space according to a patented algorithm.

Each loudspeaker channel has its own dedicated audio path through the DSP and amplification which means that each loudspeaker, or group of loudspeakers, can have their own unique set of filters.

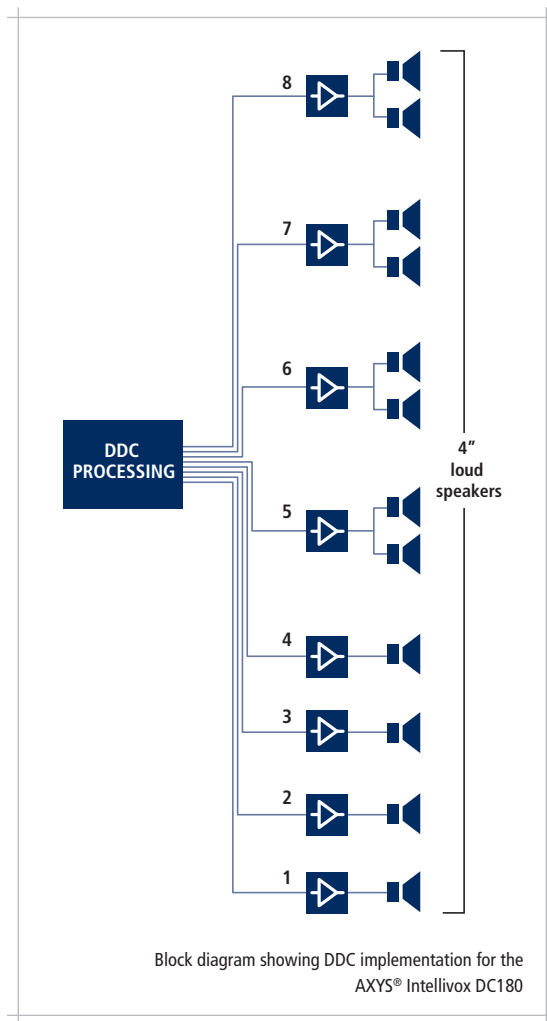

This technology enables users to electronically manipulate the vertical dispersion of an Intellivox array.

The Intellivox DDC2.0 range has the same beam steering parameters as its predecessors but with enhanced functionality and audio quality thanks to Duran Audio's new C6x DSP board.

What does DDC2.0 have to offer?

The beam steering capability of the Intellivox means that you can maintain even coverage across the listening plane whilst steering the beam away from surfaces that may cause unwanted reflections.

This results in a very high direct to reverberant sound ratio which is essential for achieving acceptable levels of speech intelligibility within reverberant spaces. One way to visualise the dispersion is to imagine a pancake of sound coming from the array, by adjusting the elevation angle we can aim the pancake up or down from the acoustic centre. This technique also means that, unlike mechanically aimed passive arrays, the back radiated energy is also controlled. This control means that electronically aimed Intellivox arrays add far less energy to the reverberant field compared to conventional systems.

Continued...

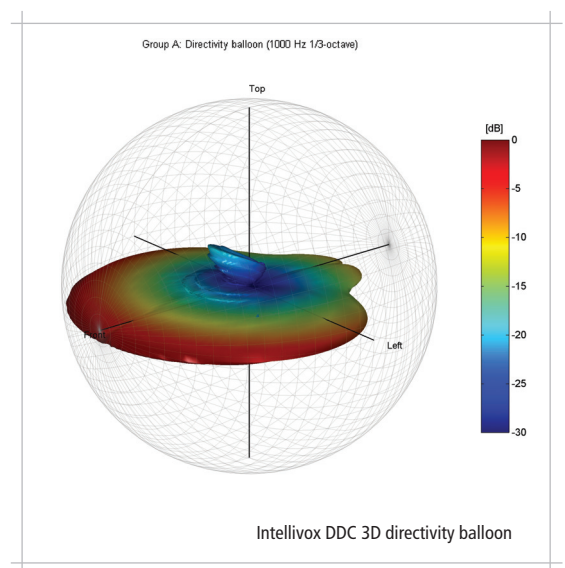

Intellivox DDC2.0 (Digital Directivity Control)

However, this is not the only benefit of the technology. DDC can also offer even SPL distribution over large distances. A well designed DDC installation can offer as little variation as 1 dB across the listening area. Taking an Intellivox DC500 as an example one can measure the SPL at 5 m and then measure again at 50 m and see as little as 1 dB variation.

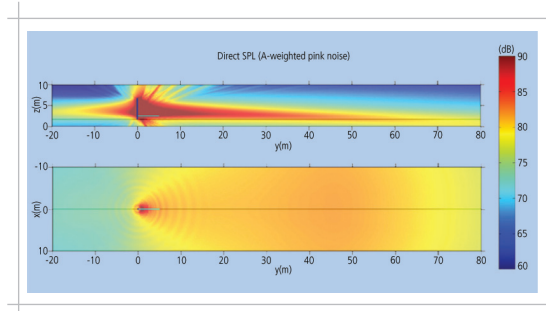

And for outdoor applications DDC technology can also offer solutions to problems associated with environmental noise pollution.

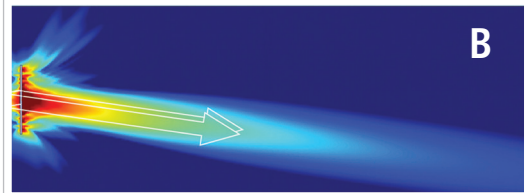
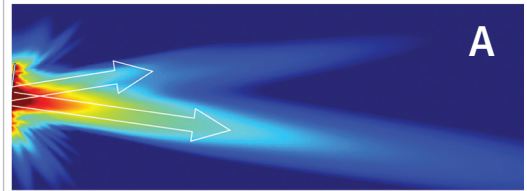
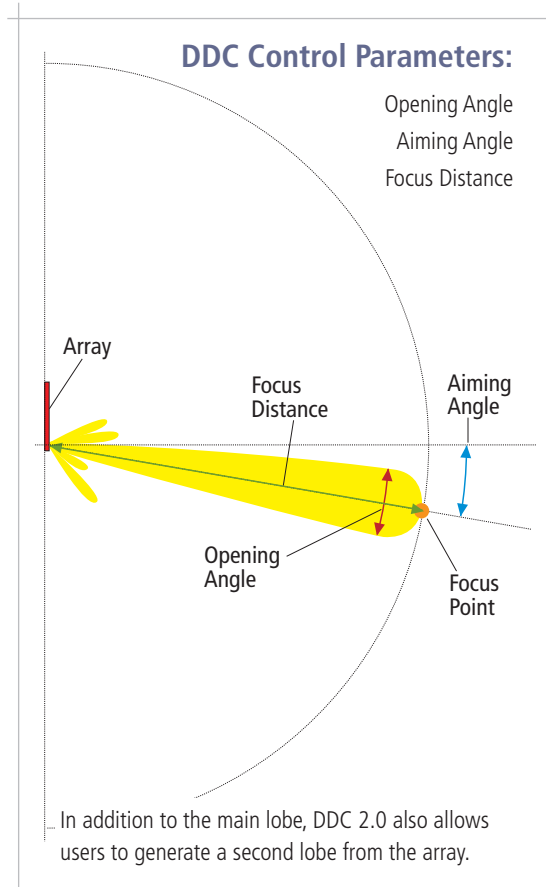

Mechanically aimed (A) versus electronically aimed (B) radiation pattern of a loudspeaker array mounted against a vertical surface.

The Intellivox is a digitally controlled loudspeaker which focuses the sound where you want it, at the listener.

In visual terms it can be thought as a spot light as opposed to a flood light. Intellivox loudspeakers have a very narrow vertical coverage angle and a very wide horizontal coverage angle. In large reverberant spaces this type of loudspeaker has many benefits:

- The sound is digitally aimed at the listener
- There is less sound reflected from walls and ceilings therefore you hear less reflections.
- It is highly efficient at distributing the available power from the loudspeaker
- The SPL of the loudspeaker is approximately the same if you are close or if you are 60 m away

The result is a very natural, clear and direct sound, which is essential for achieving the required levels of speech intelligibility and getting your announcement understood.

Intellivox