

User Guide

AXYS® UniAmp Power Amplifier Module
Model 700

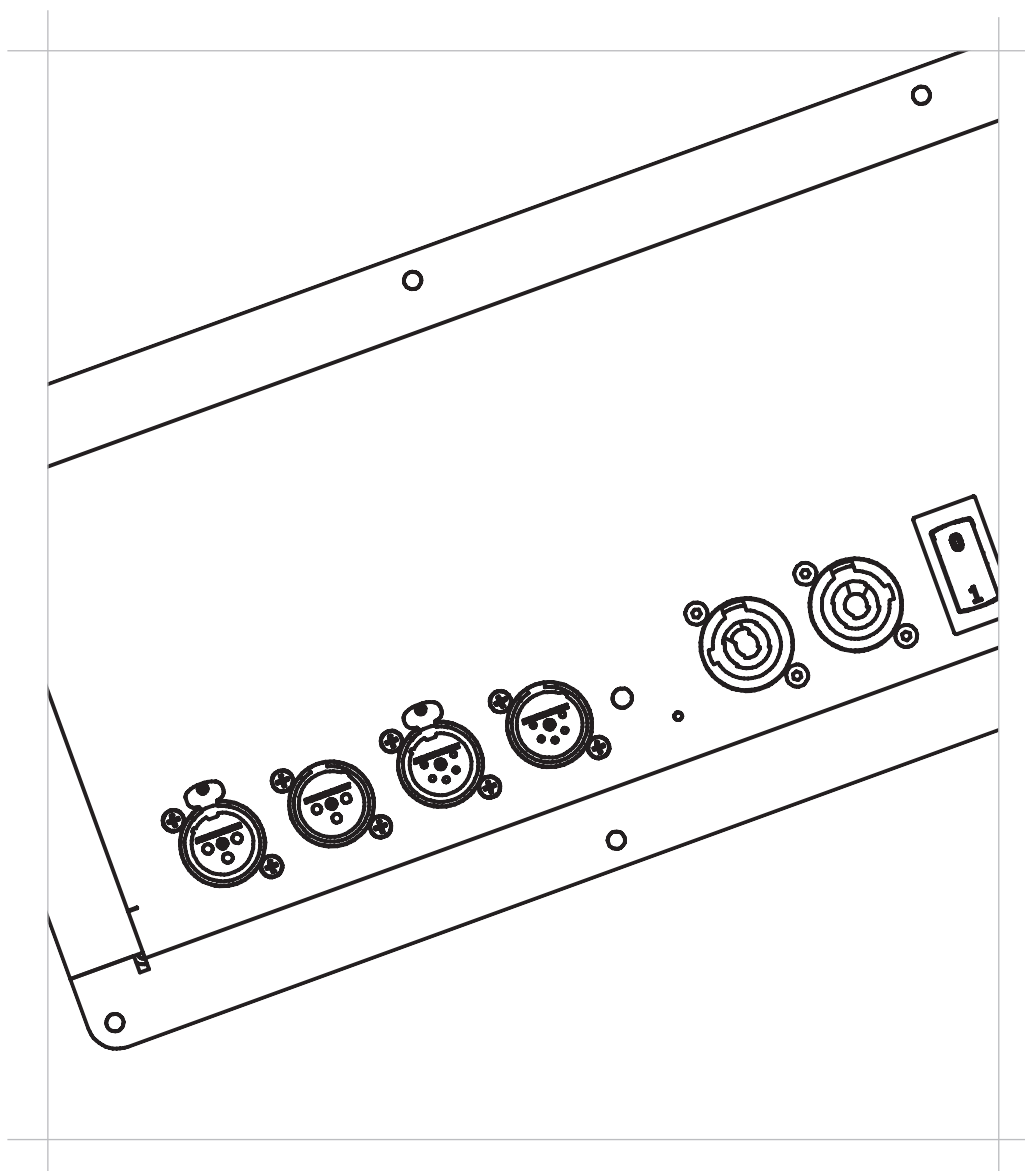

REFERENCE TO EC STATEMENT OF CONFORMITY

This document confirms that products manufactured by Duran Audio bearing the CE label meet all the requirements in the EMC directive 2004/108/EC and LV directive 2206/95/EC laid down by the Member States Council for adjustment of legal requirements. Furthermore the products comply with the rules and regulations from 30 August 1995 referring to the electromagnetic compatibility of devices. Duran Audio products bearing the CE label comply with the following harmonised or national standards:

EMC:

EN 55103-1 :1997

EN 55103-2 :1997

Safety:

IEC 60065 :2002

Mains Harmonics:

EN 61000-3-2 :2001

Insulation:

Class1

Duran Audio BV

Koxkampseweg 10

5301 KK Zaltbommel

The Netherlands

Tel: +31 418 515583

Fax: +31 418 518077

Zaltbommel, February 2009.

USER'S NOTICE AND DISCLAIMER:

No part of this manual including the software described in it may be reproduced, transmitted, transcribed, stored in a database system or translated without the express written permission of Duran Audio BV.

Documentation kept by the end user for back-up purposes is excluded from the above.

All products and corporate names mentioned in this manual may be registered trademarks or copyrights of their respective companies. They are used here for indicative purposes only.

The information contained in this manual has been carefully checked for accuracy; however no guarantee is given with respect to its correctness. Duran Audio BV accepts no responsibility or liability for any errors or inaccuracies that may appear in this manual or the products and software described in it.

Specifications and information contained in this manual are subject to change at any time without notice.

© 2009 Duran Audio BV. All rights reserved.

TABLE OF CONTENTS

Reference to Statements of Conformity	2
User’s Notice and disclaimer	2
1. Important Safety Instructions	4
2. Introduction.	5
Applicable models and variants	5
3. Connector and wiring details	6
Connector panel diagram	6
AC Mains	6
Audio connections	7
Network connections	8
4. Presets.	8
Recalling Presets	8
5. Reset	9
6. Other	9
Status LED	9
Circuit breaker	9
Cooling.	9
7. Configuring with WinControl	10
Connecting to a PC.	10
Basic software options	10
8. Appendix	11
Network cables.	11
Specifications	11

1. IMPORTANT SAFETY INSTRUCTIONS



This symbol is intended to alert you to the presence of uninsulated dangerous voltages within the product's enclosure that may be of sufficient magnitude to constitute a risk of electric shock.



This symbol is used throughout this manual and is intended to alert you to the presence of important instructions.

- 1) Read these instructions.
- 2) Keep these instructions.
- 3) Heed all warnings.
- 4) Follow all instructions.
- 5) Do not use this apparatus near water.
- 6) Clean only with dry cloth.
- 7) Do not block any ventilation openings. Install in accordance with the manufacturer's instructions.
- 8) Do not install near any heat sources such as radiators, heat registers, stoves, or other apparatus (including amplifiers) that produce heat.
- 9) Do not defeat the safety purpose of the polarised or grounding-type plug. A grounding-type plug has two blades and a third grounding prong. The wide blade or the third prong are provided for your safety. If the provided plug does not fit into your outlet, consult an electrician for replacement of the obsolete outlet.
- 10) Protect the power cord from being walked on or pinched particularly at plugs, convenience receptacles, and the point where they exit from the apparatus.
- 11) Only use attachments/accessories specified by the manufacturer.



12) Use only with the cart, stand, tripod, bracket or table specified by the manufacturer, or sold with the apparatus. When a cart is used, use caution when moving the cart/apparatus combination to avoid injury from tip-over.

13) Unplug this apparatus during lightning storms or when unused for long periods of time.

14) Refer servicing to qualified service personnel. Servicing is required when the apparatus has been damaged in any way, such as power-supply cord or plug is damaged, liquid has been spilled or objects have fallen into the apparatus, the apparatus has been exposed to rain or moisture, does not operate normally, or has been dropped.



Warning -To reduce the risk of fire or electric shock, do not expose this apparatus to rain or moisture.

Warning - To disconnect this apparatus from the mains power supply, turn off the power at the switch labelled Circuit breaker on the connector panel and remove the connector from the mains input socket labelled Mains Power Input.

Warning - Do not expose the internal backup battery to excessive heat such as sunshine, fire or the like. Note that this battery is not user-replaceable.

2. INTRODUCTION

This guide describes the operating procedures for the AXYS® UniAmp 700 power amplifier module.

The UniAmp 700 is a mains-powered power amplifier module incorporating a DSP (Digital Signal Processing) section. It has a single input and multiple speaker outputs, the number being model-dependent. The DSP section acts as a multi-band crossover and also controls beamforming and beamshaping, per-channel levels, delays, limiting action, etc.

The DSP may be configured to suit individual applications and requirements via AXYS®'s WinControl software application. This level of configuration should not be confused with the per-model factory hardware configuration referred to in the next section (Applicable models and variants). WinControl also permits constant monitoring of all units in a multiple-cabinet system during operation. WinControl is available as download from <http://www.duran-audio.com/software/WinControl.html>.

This guide does not cover any aspects of the host loudspeaker system or installation thereof; these topics are the subject of a separate Installation Manual, supplied with each loudspeaker.

APPLICABLE MODELS AND VARIANTS

The UniAmp 700 is the power amplifier module fitted as standard to the following AXYS® powered loudspeakers:

Target range:

U-16

Scope^{G2} range:

T-2112

T-2115

UB-25

Source^{G2} range

T-07

B-07*



IMPORTANT –Each UniAmp 700 is configured in the factory to suit the loudspeaker type in which it is to be installed. These configuration differences are at hardware level and are significant, and it is NOT possible to interchange UniAmp 700 modules between loudspeaker types.

The UniAmp 700 has no user-serviceable parts, and no attempt should be made to remove a module from its host enclosure. Please contact your AXYS® distributor in the event of faulty operation.

**Note that model B-07 can also be used as part of a Scope^{G2} configuration.*

3. CONNECTOR AND WIRING DETAILS

CONNECTOR PANEL DIAGRAM

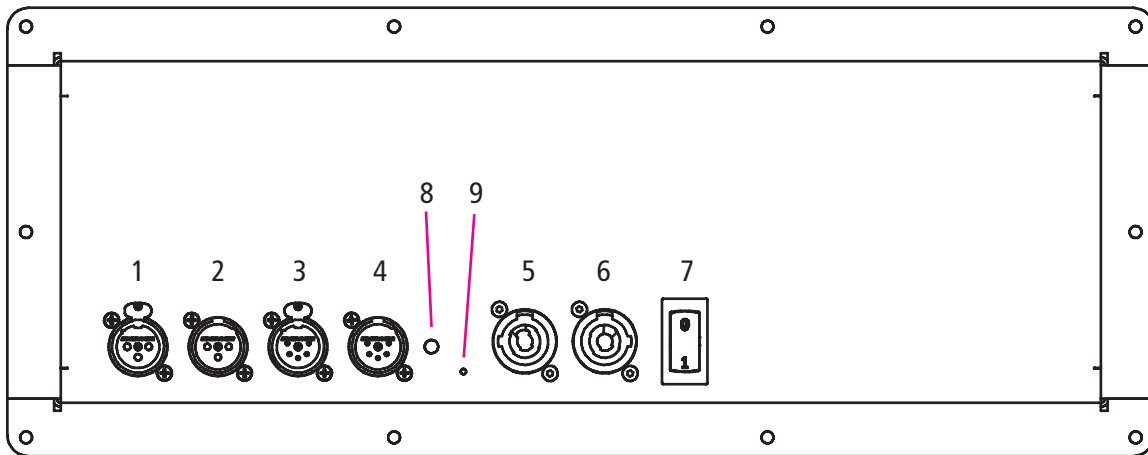

- 1 Audio input connector
- 2 Audio link connector
- 3 RS-485 network input connector
- 4 RS-485 network link connector
- 5 AC mains input connector
- 6 AC mains link connector
- 7 Mains switch/resettable circuit breaker
- 8 Status LED
- 9 Reset and Preset Control (access hole)

AC MAINS

Two Neutrik® PowerCon® chassis connectors are fitted to the UniAmp 700. The Input connector (coloured blue) is a Neutrik® Type A, and is intended for connection of the AC mains supply; the Link connector (coloured grey) is a Neutrik® Type B, and is to facilitate connection to another module in an adjacent enclosure.



Note that the Link connector is not independently fused.

The full-load power consumption of the amplifier module is 700 VA under typical normal operating conditions. When "daisy-chaining" AC mains between several enclosures of the same type using the Input and Link connectors, ensure that the current capacity of the supply is sufficient for ALL amplifiers in the chain, and additionally, that the total current drawn by all the amplifiers does not exceed 20 A (the maximum rated current of the PowerCon® connectors).



In practice, this means that the maximum number of amplifiers (including the first one) that may be daisy-chained in this way is six (230 V operation) or three (115 V operation).

Only wire AC mains connectors according to the table below:

PIN	CONNECT	COLOUR (Europe)	COLOR (US)
L	Live	Brown	Black
N	Neutral	Blue	White
⏏	Earth (Ground)	Green/Yellow	Green

The PowerCon® connectors are plugged and unplugged as shown in the diagram below.

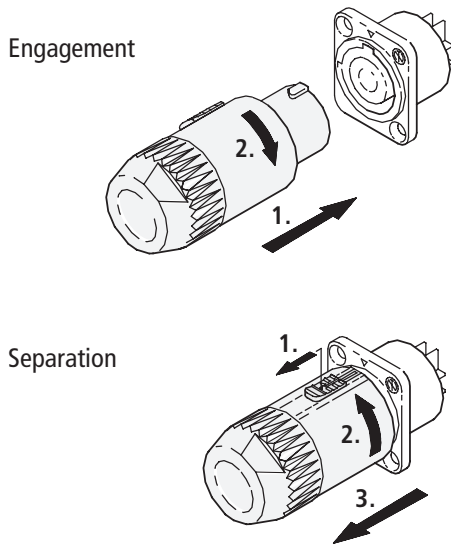

The UniAmp 700's audio input and output are twin transformer-balanced, and are designed to operate at a nominal level of 0 dBV. Balanced system interconnection, using twin-and-screen microphone cables is strongly recommended.

Wire the audio connectors as follows:

PIN	CONNECT	COLOUR
1	Screen	Cable Screen
2	Hot (+)	Red*
3	Cold (-)	Black*

* Typical colours, may vary with cable make and type.



IMPORTANT – The PowerCon® connectors should never be plugged or unplugged when there is power on the connectors, regardless of whether the amplifier is switched on or not. ALWAYS ensure that the mains supply is turned off before inserting or removing either PowerCon®.

AUDIO CONNECTIONS

Two latching 3-pin XLR connectors are fitted for audio interconnections. The Input connector (female) is for connection of an audio input signal; the Link connector (male) is hardwired to the input connector, and facilitates easy connection to another amplifier in an adjacent enclosure.



NETWORK CONNECTIONS

Two latching 5-pin XLR connectors are fitted for RS-485 network interconnections. A PC running WinControl may be connected, via an appropriate interface (either RS-232 to RS-485 or USB to RS-485) to the Input connector, if control and monitoring during operation are required. The Link connector (male) is to facilitate easy connection to another WinControl-supported device (e.g. an adjacent enclosure).

The network connectors should be wired as follows:

PIN #	Function
1	Screen
2	Data Tx +
3	Data Tx -
4	Data Rx -
5	Data Rx +



See page 11 for information regarding suitable network cable types. See Section 7 (Configuring with WinControl) for more information about network operation and software options.

4. PRESETS

The UniAmp 700's DSP section includes 8 Presets; memory locations in which sets of configuration parameters can be stored. These permit the loudspeaker cabinet to be "fine-tuned" to suit different types of programme material and venue.

When a settings file is loaded into the unit from a PC, the user can specify in WinControl which Preset memory it will be loaded into.

RECALLING PRESETS

The simplest method of recalling a previously-saved Preset is via WinControl. This necessitates a network connection to the loudspeaker system. Refer to the WinControl Help files for further information.

If a network connection is not in place, or a PC with WinControl is unavailable, Presets may be recalled manually using the Reset & Preset Control button*. This button is hidden behind a small access hole on the amplifier module's connector panel, and can be accessed with an implement such as a fine jewellers' screwdriver or a straightened-out paper clip.

A single short press (< 1 sec) on this button will increment the current Preset number, i.e. if the system is currently running Preset 2, pressing the button will load Preset 3. While the button is pressed, the Status LED will change colour from green to red. Loading of the next Preset is confirmed by the LED flashing the appropriate number of times, i.e., it will flash 3 times when Preset 3 is loaded. Using this method, repeated button presses will load each Preset in turn.



Note that the amplifier module always powers-up with the last-used Preset active. Note also that a long (> 1 sec) button press has a different function (see following page).

*Please note that this feature may not be available on Target U-16 enclosures with early serial numbers. Please contact your AXYS® dealer for more information.

5. RESET

One of the eight Preset memories acts as a “default” memory, referred to as the “preferential preset” by WinControl. Users are recommended to store a known base configuration in this Preset, and to protect it via WinControl. This Preset may be reloaded by a long (> 1 sec) press on the Reset & Preset Control button (but see note on previous page regarding early U-16 serial numbers).

Resetting the UniAmp 700 may also be carried out via WinControl; see the WinControl Help files for more information.

6. OTHER

STATUS LED

The bi-colour Status LED has several functions:

1. To indicate that power is being applied to the unit, the LED shows green for normal operation.
2. To indicate a fault state. The conditions for a fault state are defined as part of the WinControl settings file. If the conditions are met, the LED illuminates red and an error indication is also communicated via WinControl.
3. To confirm which Preset is being loaded (see Recalling Presets, Section 4).
4. Unit identification: if the LED is set (in software) to duplicate the functions of the LED on the front of the enclosure, it will also confirm unit identity when requested by WinControl.

CIRCUIT BREAKER

The amplifier module’s mains on/off switch is also a resettable 6.3 A circuit breaker. If the module draws current in excess of the rating from the AC mains (as may happen in a fault condition), the circuit breaker will trip, disconnecting the power. The fault condition should be identified and rectified before attempting to reset the breaker. Note that under extreme fault conditions, it may not be possible to reset the breaker.

There are no user-replaceable fuses within the Target System amplifier module.

COOLING

Loudspeaker enclosures equipped with the UniAmp 700 include fan-assisted cooling of the electronic assembly. The direction of airflow is from intakes at the front of the enclosure, with exhaust through slots in the connector panel. The fan is automatic and is controlled via a “whisper algorithm” via the DSP section, which adjusts the fan speed according to temperature and input signal level. Care should be taken in installation not to restrict the airflow.

7. CONFIGURING WITH WINCONTROL

Correct operation of a UniAmp 700 module may be confirmed using WinControl software.

A full description of WinControl is beyond the scope of this manual and further information is available in the application's Help files. Instructions on how to install WinControl on a PC are included with the Program Set. Instructions on the use of the AXYS® RS-485 interface are included with the interface itself.

CONNECTING TO A PC

The PC connects to the amplifier module via an RS-485 interface adapter. (Two versions of adapter are available from Duran Audio, for connecting to PCs either via a USB or an RS-232 port). Use either a 5-pin XLR female to 5-pin XLR male cable or a 9-pin Dsub to 5-pin XLR male. These cables (5 m in length) are supplied with the WinControl Program Set, the type depends on the RS-485 interface type. The RS-485 interface should then be connected to either the PC's 9-pin COM port (in the case of a RS-232 to RS-485 interface) or a USB port (in the case of a USB to RS-485 interface).

BASIC SOFTWARE OPTIONS

WinControl allows the various parameters of the UniAmp's DSP section to be set according to the installer's wishes. This enables the performance of the loudspeaker enclosure to be accurately optimised to suit both the venue and the type of programme material being handled (speech, rock, opera, etc.) In the case of the Target U-16 enclosure, AXYS® DDA (Digital Directivity Analysis) may be employed to model the room's acoustics accurately, and the results of this analysis then used to optimise the array's performance.

The particular set of parameters which can be adjusted via WinControl varies with loudspeaker model. Typically, it includes delay, gain and multi-band parametric EQ.

In addition to the parameters determining the audio performance, the various Preset memories may have alternative configurations stored in them, and recalled as required. Unit monitoring may also be configured, with the conditions for a fault state to be signalled being registered. Additionally, multiple loudspeaker units may be 'grouped' together in software, allowing very rapid adjustment of the overall loudspeaker array performance.

Full details of the options available within WinControl are available in the application's Help files.

8. APPENDIX

NETWORK CABLES

The type of cable necessary for correct operation of the RS-485 network is twin twisted pair with each pair individually shielded. Numerous cables of this type are readily available and cables broadly meeting the specifications given below (which are those of a common commercially-available cable) are likely to be suitable.

PARAMETER	VALUE
Characteristic impedance	100 ohms
Capacitance (core to core)	41 pF/m
Capacitance (core to screen)	72.5 pF/m
DC resistance (core)	78.7 ohms/km
DC resistance (screen)	59.1 ohms/km

Additional information regarding network connections and grounding strategies may be obtained at :

http://www.duran-audio.com/pdfs/downloads/papers/grounding_strategy.pdf

SPECIFICATIONS

Please refer to the download section of our website for product specifications.



IS A REGISTERED TRADE MARK OF

DURAN AUDIO BV

Koxkampseweg 10, 5301 KK Zaltbommel, The Netherlands.

tel. +31 418 515583 fax. +31 418 518077

<http://www.duran-audio.com> Info@duran-audio.com